



# 2013 AUSTRALIAN OFF ROAD CHAMPIONSHIP Sporting Regulations



*Photo courtesy of Sean McTigue*



Version 1	B13-028

		<b>2013 Australian Off Road Championship Sporting Regulations</b>	
<b>1</b>		<b>GENERAL</b>	<b>3</b>
<b>2</b>		<b>ADVERTISING</b>	<b>3</b>
<b>3</b>		<b>CHAMPIONSHIP SCHEDULE</b>	<b>3</b>
<b>4</b>		<b>EVENTS</b>	<b>3</b>
	4.1	Starting Order	<b>3</b>
	4.2	Seeding	<b>4</b>
	4.3	Competition Numbers	<b>4</b>
	4.4	Timing	<b>4</b>
	4.5	Finishers	<b>5</b>
	4.6	Judges of Fact	<b>5</b>
	4.7	Protests	<b>5</b>
	4.8	Postponement, abandonment and cancellation	<b>5</b>
	4.9	Outside servicing	<b>5</b>
	4.10	Refuelling	<b>5</b>
	4.11	Reconnaissance	<b>6</b>
	4.12	Starting position after failing to finish a section	<b>6</b>
<b>5</b>		<b>REGISTRATION</b>	<b>6</b>
<b>6</b>		<b>COMPETITOR/CREW/DRIVER ELIGIBILITY</b>	<b>7</b>
<b>7</b>		<b>CREWS</b>	<b>7</b>
<b>8</b>		<b>CREW ATTIRE</b>	<b>7</b>
<b>9</b>		<b>CREW BRIEFING</b>	<b>8</b>
<b>10</b>		<b>VEHICLE ELIGIBILITY</b>	<b>8</b>
<b>11</b>		<b>SCRUTINY</b>	<b>8</b>
<b>12</b>		<b>PARC FERMÉ</b>	<b>9</b>
<b>13</b>		<b>CHAMPIONSHIP &amp; SERIES POINTS AND AWARDS</b>	<b>9</b>
	13.1–13.7	Outright and Class Championship	<b>9</b>
	13.8	Tri-Series	<b>10</b>
	13.9	Co-drivers/Navigators	<b>10</b>
	13.10	Scheduled Distance	<b>11</b>
	13.11	Shortened Events	<b>11</b>
	13.12	Non Registered Crews/Drivers	<b>11</b>
	13.13	Ties	<b>11</b>
<b>14</b>		<b>PRESENTATION OF AWARDS</b>	<b>11</b>
<b>15</b>		<b>IMAGE AND VISION RIGHTS AND IN CAR CAMERA'S</b>	<b>11</b>
<b>16</b>		<b>MEDIA CONFERENCE</b>	<b>12</b>
<b>17</b>		<b>PRIZE MONIES</b>	<b>12</b>
<b>18</b>		<b>JUDICIAL PROCEDURES</b>	<b>12</b>
<b>19</b>		<b>PENALTIES</b>	<b>14</b>
<b>APPENDIX A</b>		<b>INFRINGEMENT NOTICE</b>	<b>15</b>

# 2013 Australian Off Road Championship

## Sporting Regulations

### 1. GENERAL

Each event in the Australian Off Road Championship shall be held under the provisions of the International Sporting Code of the FIA, the National Competition Rules of CAMS, General Conditions for all Titles, Off Road Standing Regulations, relevant technical regulations, these Sporting Regulations and the Supplementary Regulations published by the organisers of each event, as well as any further regulations or instructions which may be issued.

### 2. ADVERTISING

- 2.1 By entering any event in the Championship, persons and corporations agree to refer to it only by its full title, "The 2013 Australian Off Road Championship".
- 2.2 Any promotional material must include the full title.
- 2.3 Each vehicle is required to display the CAMS logo on each side of the vehicle, together with any series sponsorship signage which may be required.
- 2.4 An event organiser may also require each competitor to display signage promoting the event sponsor; in such cases this requirement is to be included in event supplementary regulations, and the organisers shall provide this signage to competitors.

### 3. CHAMPIONSHIP SCHEDULE

The 2013 Australian Off Road Championship shall consist of the following events:

Round	Date	Event	State	Type
1	30-31 March	Hyden	WA	Long Course
2	8-9 June	Finke	NT	Long Course
3	27-28 July	Baroota	SA	Long Course
4	14-15 September	Coffs Harbour	NSW	Long Course
5	26-27 October	Lockyer Valley	QLD	Long Course

### 4. EVENTS

#### 4.1 Starting order

- (i) The starting order for the first section shall be determined by a prologue and/or a shootout
- (ii) The starting order for the second and any subsequent sections shall be based on the outright finishing order of the preceding section, as varied by the inclusion of any crews/drivers restarting the event as provided for in Article 4.12 of these regulations.
- (iii) After consultation with AORCom, Organisers shall advise each crew/driver of the prologue start order upon seeding of each class in the prologue field. This advice is to be made available not later than 24 hours before the first briefing to allow crews/drivers to identify potential problems. The latest acceptable time for bringing such problems to the attention of the organisers is the scheduled start time for the first crew briefing.

- (iv) Other than as provided for in the preceding paragraph, each crew/driver shall start the prologue at the times allocated to them by the organisers, without exception.
- (v) For the prologue, each vehicle shall be grouped by class.
- (vi) The crew and vehicle combination completing the prologue course in the least time shall start first, followed by the remainder of the field in increasing order of time taken over the prologue course.
- (vii) Where specified in the Supplementary/Further Regulations, a Shootout shall take place. The Shootout shall determine the starting position of each competitor who qualifies for the shootout.
- (viii) The prologue shall be conducted in daylight.

#### **4.2 Seeding**

- (i) A crew/driver not finishing the prologue may, on application, be seeded.
- (ii) Seeding shall be on the basis of the average of a driver's three previous prologue results, relative to the rest of the field.
- (iii) No driver who has applied to be seeded may be seeded within the top 10% of vehicles starting the event, if fewer than 100; and not within the top 10 vehicles if more than 100.
- (iv) There shall be no right of appeal against any decision with regard to seeding.
- (v) Except as otherwise provided for in Article 7 of these regulations, the driver/co-driver combination which attempts the prologue (or applies for seeding) must start the event in the same respective roles.

#### **4.3 Competition numbers**

- (i) Each driver shall use their current annual national competition numbers allocated by CAMS. If a permanent number has not been allocated, the organiser shall allocate a competition number to be used for the event.
- (ii) Competition numbers must comply with article GR30 of the General Requirements for Off Road Vehicles, in the CAMS Manual of Motor Sport.
- (iii) The numbers 1, 2 & 3 are reserved for the exclusive use of the first three drivers in the preceding year's AORC.  
The first three competition numbers in each class (e.g. 101, 102, 103, 201, 202) are reserved for the exclusive use of the first three drivers in each class in the preceding year's AORC.  
A driver who is eligible to use one of these numbers due to achieved results shall utilise the reserved number at each AORC event of the following year.  
A driver required to utilise 1, 2, or 3 or the first three competition numbers in each class may apply to CAMS for their existing competition number to be reserved free of charge.

#### **4.4 Timing**

- (i) Timing shall be to the hundredth of a second using the 24 hour system.
- (ii) Each vehicle shall be timed as their front wheels pass the timing marker of the control, or if an electronic beam is utilised, when the beam is broken.
- (iii) The results of each event shall be determined by the total elapsed time taken by vehicles for all sections of the event, to which have been added any penalties.

#### **4.5 Finishers**

A finisher of the event is defined in the Off Road Standing Regulations Article 10 and applies to each vehicle in the event.

#### **4.6 Judges of Fact**

Each control official shall be a judge of fact with regard to time and direction of entry into controls.

#### **4.7 Protests**

Each protest shall be lodged in accordance with the provisions of Part XII of the NCR.

#### **4.8 Postponement, abandonment and cancellation**

The organising committee may postpone, abandon or cancel the event at any point in accordance with the NCR; or cancel the event should the number of entries received be less than the minimum as specified in the event supplementary regulations.

#### **4.9 Outside servicing**

- (i) Servicing of a competing vehicle during an Australian Off Road Championship event other than in the designated pits is prohibited. This prohibition shall not apply where such servicing;
  - (a) is carried out only by a crew member of a vehicle which started in the competition (that section), whether it be the vehicle in question or another competing vehicle,
  - (b) uses no parts or equipment other than those which have been carried from the pits, after the start of the event, in a vehicle which started the event (in either the vehicle in question or another competing vehicle), or which have been carried from the pits by a crew member of the vehicle in question, on foot, without any assistance outside the pit/paddock area,
  - (c) uses any article or material which might normally be found in the region, eg water, fencing wire, string and the like, (other than as provided for above this does not apply to automotive components or tools) and/or
  - (d) is rendered by an official recovery crew, with that crew's agreement, and which takes the form of:
    - towing to the next accessible passage control, or the next recovery point,
    - provision of tools, but NOT parts, and/or
    - provision of water.
- (ii) Notwithstanding the provisions of Art 4.9 (i), the Clerk of the Course or his nominated deputy may provide written permission for pit crews to provide assistance at a passage control or recovery point, or for crews to be carried from the course to the pits and back again; this permission being valid for one instance only.

#### **4.10 Refuelling**

The Organiser is to establish a designated "refuelling area", specifically set aside for the purpose of refuelling during competition. It is strongly recommended that competitors utilise some form of earth spike to reduce the possibility of static build up. Except as otherwise specifically provided for in the regulations applicable to the event, refuelling outside of these areas is prohibited.

If a vehicle runs out of fuel on the course the Clerk of the Course, or his nominated deputy, may give written permission for that vehicle to be refuelled on the course, provided always that safety is not compromised in any way.

#### 4.11 Reconnaissance

- (i) The Organiser is to provide each crew/driver with the opportunity to undertake reconnaissance of the entire course, and the prologue course, in daylight within 48 hours of the start of the event.
- (ii) It is recommended that each driver be allowed to use either their competition vehicle or suitable road car, with those using non-competition vehicles not being allowed to start until those in competition vehicles have had reasonable opportunity to do so. Where competitors are unable to use their competition vehicle due to registration requirements and where they do not have access to a suitable road vehicle, competitors may make application to the Organisers no later than 7 days prior to the event to be transported over the competition course during reconnaissance as arranged by the Organiser.
- (iii) Each occupant in a vehicle being utilised on the reconnaissance shall wear a seat belt at all times.
- (iv) Each competition vehicle utilised in reconnaissance shall have first passed scrutiny. Where this vehicle is not fitted with a windscreen, a helmet and visor complying with Schedule D shall be worn by each occupant.
- (v) Each non-competition vehicle participating in the Reconnaissance must display their competition number on the passenger side front windscreen of the vehicle in a position that does not interfere with the driver's visibility.  
Each competitor shall provide their own competition numbers to the following specification:
  - \* Size 150mm
  - \* Colour "Dayglo" yellow with no background
  - \* Typestyles "Helvetica Bold", "Zurich bold" and "Arial Bold" as per Schedule K

#### 4.12 Starting position after failing to finish a section

- (i) A crew/driver who fails to finish a section may start a subsequent section provided they are able to satisfy the Chief Scrutineer that the vehicle is in a safe and competition ready condition; and shall, should he make application within the prescribed timeframe, be seeded.
- (ii) Such a seeding is to be effected using the same criteria as for a driver who is seeded after failing to finish a prologue. No driver who has applied to be seeded may be seeded within the top 10% of vehicles starting the event if fewer than 100; and not within the top 10 vehicles if more than 100.
- (iii) Such a seeding is to be referred to the Stewards for approval.
- (iv) There is no right of protest or appeal against any decision with regard to seedings.

### 5. REGISTRATION

- (i) Registration for the 2013 Australian Off Road Championship is required in order to be eligible to score Championship points. The form is available via the CAMS website.
- (ii) The driver and nominated co-driver shall be eligible to score points in events conducted after the application has been received, and this must be received by CAMS prior to the completion of documentation. At an AORC event, registration applications shall be lodged with the Stewards prior to the conclusion of pre-event paperwork.

- (iii) Any AORC registration form that does not specify a co-driver that is to be registered for AORC points or does not update a change to the nominated co-driver for points will result in no co-driver points being awarded.
- (iv) Championship points will only be allocated to a co-driver that competes the entire event as co-driver.
- (iv) A non-registered crew/driver may enter an AORC event, but shall only be eligible for event results and event awards (not points) and shall be disregarded for the compilation of the AORC point score.

## **6. COMPETITOR/CREW/DRIVER ELIGIBILITY**

- (i) For competition licence requirements refer to the General Regulations of CAMS, "Licences" in the CAMS Manual of Motor Sport.
- (ii) At least one member of each crew must hold a valid civil driver's licence, or be at least 18 years of age.
- (iii) the entry list for each event shall reflect which competition/s each entered crew is eligible for and the co-driver/navigator nominated for AORC points. The entry list shall be submitted to CAMS for approval prior to publication.

## **7. CREWS**

- (i) Except for Pro Buggy, Prolite Buggy and Extreme 2WD vehicles fitted with only one seat, where the crew consists of only the driver, two persons shall comprise the crew of any competing vehicle at any time and shall be nominated as "driver", "co-driver" or "navigator" as appropriate. The participation of more than one navigator appropriately nominated on the entry form is permitted.
- (ii) Crew changes are permitted, subject to the following conditions.
  - (a) A driver who starts the event may be replaced only by the co-driver. The original driver may resume driving the same vehicle later in the event.
  - (b) A co-driver may be replaced by either the driver who started the event in that vehicle, or by a navigator: the latter who may navigate only.
  - (c) To be classified as a finisher, a vehicle must be driven by the driver who starts the event in that vehicle for at least 75% of the distance specified by event organisers. Where this is not possible due to the event format, 50% of the distance specified shall be the minimum portion of the event required to be driven by the driver who starts the event, who shall score AORC points.
  - (d) No driver may be nominated as a number one driver in more than one vehicle in an event.
- (iii) Where a co-driver or navigator, becomes incapacitated through either sickness, injury or other extenuating circumstances prior to or during an event that person may, subject to the permission of the Clerk of the Course, be replaced by a co-driver or navigator who has already been entered as such on an entry form as a crew member for another entry in that event.
- (iv) Where the requirements for drivers and navigators vary between State Championship and National Championship in dual status events, these variances must also appear in event supplementary regulations. Where a conflict exists, the AORC requirements shall take precedence.

## **8. CREW ATTIRE**

During competition, each crew member is required to wear apparel which complies with the standards listed in Table 2.3 (National) of Schedule D – Apparel of the CAMS Manual

of Motor Sport. The wearing of a head restraint in accordance with Schedule D, Article 3.2 is highly recommended.

## 9. CREW BRIEFING

- 9.1 There are to be two briefings for crews/drivers; at least one on the day of, and before, the prologue, and one before competition on subsequent days of the event.
- 9.2 Attendance at each crew briefing is compulsory for each crew member. The Organiser shall provide a list showing vehicle number, and the names of each driver, co-driver and navigator. Each competing crew member shall sign on. The sign-on sheets are to be made available to crews/drivers for a period commencing at least 20 minutes prior to the scheduled start time for each crew briefing, and shall be removed at the scheduled start time.
- 9.3. The time and place of crew briefings is to be specified in Supplementary Regulations. Cases of non-attendance are to be referred to the Stewards by way of a formal charge, which may result in a penalty.

## 10. VEHICLE ELIGIBILITY

- 10.1 Each vehicle shall comply with the requirements of the "Off Road" section of the CAMS Manual of Motor Sport, and be eligible for one of the listed classes in article 4.2 of the Off Road Standing Regulations.
- 10.2 A space 140mm high x 500mm wide immediately under the crew's side 'window' opening is reserved for Organiser and AORC sponsorship signage on each side of the vehicle. If this signage is not outlined in the Supplementary Regulations, competitors may utilise this space for their own purposes.

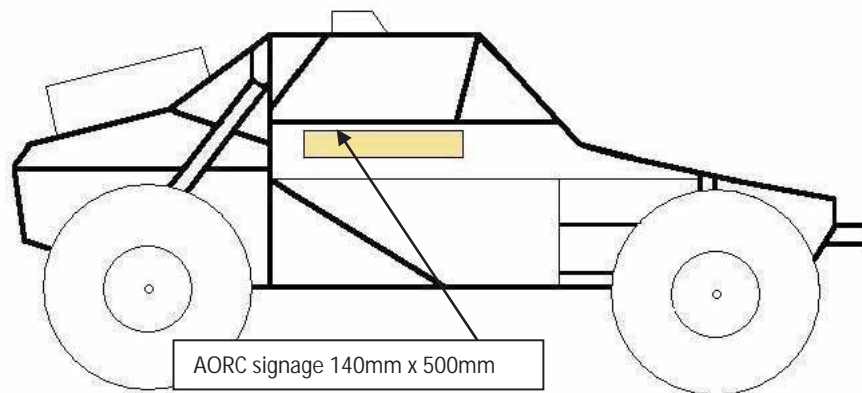

## 11. SCRUTINY

- 11.1 Each competition vehicle shall be examined by the event scrutineers prior to starting the event. The time and place for such examination shall be advised in Supplementary Regulations. Further vehicle checks may be conducted throughout the event.
- 11.2 "Regional" pre-event scrutiny may be provided, subject to the regional scrutineer being approved by the AORC Technical Commissioner prior to such scrutiny being conducted. Random checks of vehicles approved at regional scrutiny are to be conducted at events.
- 11.3 A competition vehicle may be examined for eligibility at any time before or after finishing, up to 30 minutes after the conclusion of the event.



- 11.4 Immediately upon the completion of the event, the vehicles which fill first, second and third places outright, and first place in each class, shall be impounded by the Organiser for possible post-event eligibility scrutiny. Other vehicles may also be impounded at the Organiser's or Technical Commissioner's discretion.
- 11.5 Vehicles impounded by virtue of either their outright or class finishing positions shall be held in impound for at least 20 minutes. Examination for compliance may be undertaken whilst the vehicle is impounded and competitors may be required to provide mechanical assistance to scrutineers undertaking such examinations. A safe method of fuel sampling is to be provided after the main fuel tank.

## 12. PARC FERMÉ

- 12.1 For regrouping or other reasons, vehicles may be required to be held in a *parc fermé*. Any vehicle which enters a *parc fermé* with its engine running may be restarted with assistance from officials before its release time.
- 12.2 When *parc fermé* conditions are imposed prior to the conclusion of an event (e.g. for regrouping) the *parc fermé* is to be located so that it is possible for crews/drivers to go directly to the pits on release from *parc fermé* should they wish.

## 13. CHAMPIONSHIP & TRI-SERIES POINTS AND AWARDS

- 13.1 Outright and Class points for each round shall be allocated independently. If the event is run as one section the following points shall apply:

Single Section Event									
1	2	3	4	5	6	7	8	9	10
300	276	258	240	222	204	192	180	168	156
11	12	13	14	15	16	17	18	19	20
144	138	132	126	120	114	108	102	96	90
21	22	23	24	25	26	27	28	29	30
84	78	72	66	60	54	48	42	36	30
31	32	33	34	35					
28	26	24	22	20					

- 13.2 For multiple-section events, points shall be assigned to each section based on the above table and the length of the section as a percentage of the total distance of the event. These points shall be published in event regulations and shall not be varied, except in the case of article 13.11 Shortened Events.
- 13.3 Section points shall be rounded to the nearest whole number.
- 13.4 To be credited with finishing a section a vehicle must complete all laps forming that section in accordance with article 10.3 of the Off Road Standing Regulations.
- 13.5 All rounds count toward the Outright and Class Championships.
- 13.6 The crews with the most points at the end of the Championship, for both Outright and eligible Classes, shall be deemed the winners.
- 13.7 The following Champions shall be recognised:
- (i) An outright Champion Driver and Co-driver, to be known as the Australian Off Road Champion Driver and Australian Off Road Champion Co-driver respectively, shall be recognised.

- (ii) The winner of each eligible class (listed below) shall be recognised as the Australian Off Road (*insert relevant class name*) Class Champion Driver and Co-driver respectively.
- Pro Buggy
  - Prolite Buggy
  - Super 1650 Buggy
  - Performance 2WD
  - Extreme 2WD
  - Production 4WD
  - Extreme 4WD

### 13.8 Tri-Series

The Tri-Series is a series run as part of the AORC and shall consist of the following:

- (i) For a crew to be eligible, the driver shall not have finished in the top 15 outright and shall not have won a class in the previous year's AORC.

The following drivers are not eligible for the 2013 Tri-Series:

Matt Hanson	Matthew Coleman	Gerard Reid
Brad Prout	Brad Gallard	Joe Bulmer
Lindsay Foster	Dan Bonnor	Mark Burrows
Chris Western	Raana Horan	Neville Taylor
Andrew McClelland	Darryl Smith	Terry Rose
Robert Chapman	Bernie Clohesy	Matthew Owen
Les Marshall		

- (ii) A maximum of three (3) rounds shall count towards the point score for each eligible crew member.
- (iii) The driver may nominate to compete in any three rounds of the Championship.
- (iv) The rounds in which crews shall score points shall be nominated prior to the close of documentation of the first event in which the crew wishes to score points. A list of nominated rounds for each Tri-Series registered crew shall be published.
- (v) The crew may compete in more than three rounds of the AORC, but points towards the Tri-Series shall only be scored in these three nominated events.
- (vi) The nominated rounds of the Tri-Series may be changed. The latest time to do so is prior to the completion of documentation of a nominated event. If a change is to occur at an event the Stewards must be advised or, if remote from an event, the competitor must advise the CAMS Motor Sport Coordinator - Off Road, in writing or via email, preferably by resubmission of the Tri-Series round nomination form to [offroad@cams.com.au](mailto:offroad@cams.com.au)
- (v) The Tri-Series shall have an 'Outright Tri Series' winner and an overall 'Class' winner, with points scored in the same manner outlined in Article 13.1 to 13.5.
- (vi) A trophy shall be awarded to each member of the winning crew.

- 13.9 Co-drivers/Navigators:** The first named co-driver appearing on the entry form shall be awarded the points. The point scoring co-driver/navigator shall only be eligible if he completes at least one section, or the total distance covered by the vehicle, whichever is the lesser, and provided that the vehicle is classified as a finisher.

### **13.10 Scheduled Distance**

The Scheduled Distance for each section is the distance advised in event regulations, or as otherwise approved by the Stewards and advised in writing to competitors prior to the commencement of that section.

### **13.11 Shortened Events**

Where a section is stopped or otherwise shortened after its commencement, points shall be awarded for the affected section/s as follows.

- (a) If the leading vehicle at the time has completed less than 25% of the scheduled distance, no points shall be awarded.
- (b) If the leading vehicle has completed 25%, but less than 75%, of the scheduled distance, points shall be awarded at 50% of the normal scale applicable.
- (c) If the leading vehicle has completed 75% or more of the scheduled distance, points shall be awarded as though the scheduled distance had been covered.

### **13.12 Non-Registered Crews/Drivers**

The results of each crew/driver who has not registered for the AORC are to be disregarded when compiling the Championship pointscore.

### **13.13 Ties**

- i) Championship – Outright : In the event of two competitors scoring equal points at the end of the Championship, the final positions shall be determined by the greater number of higher outright section finishing positions.
- ii) Championship - Class: In the event of two competitors scoring equal points at the end of the Championship, the final positions shall be determined by the greater number of higher class section finishing positions.
- iii) Tri Series - Outright: In the event of two competitors scoring equal points at the end of the Championship, the final positions shall be determined by the greater number of higher outright section finishing positions.
- iv) Tri Series – Class: In the event of two competitors scoring equal points at the end of the Championship, the final positions shall be determined by the greater number of higher class section finishing positions.

If this mechanism does not determine the result, a tie shall be declared.

## **14. PRESENTATION OF AWARDS**

Following each event, the Organiser is to conduct a presentation ceremony, usually in the vicinity of the finish. In order to ensure that the public and others are able to properly identify and honour the winners, a podium should be prepared.

A formal presentation function should also be held. A Crew member or a team representative is required to attend if there is likelihood of an award, or at the direct request of the Clerk of the Course.

## **15. IMAGE AND VISION RIGHTS AND IN-CAR CAMERAS**

- (i) In entering a round of the AORC, Competitors agree to assist the AORC in the promotion of the Championship and in particular, the AORC television broadcast and social media production.

- (ii) By entering a round of the AORC, the Competitor agrees to relinquish any claim or right to any images or vision recorded for the AORC broadcast or social media production, or any other material related to that broadcast or social media production.
- (iii) Any filming or any other means of recording images or vision for commercial purposes at an AORC meeting by any Competitor, is strictly forbidden unless they have the prior written permission of the AORC.
- (iv) The AORC may provide In-Car camera's to be fitted to selected cars during an event. Competitors must provided access to any AORC appointed technician, to install and service the Camera and associated equipment.

## **16. MEDIA CONFERENCE / PROMOTIONAL ACTIVITIES**

Award winning crews may be required to attend a media conference, which shall take place as close as practicable to the presentation area. Crews are reminded of their obligations to event sponsors, and should present themselves accordingly in team uniform, or with driving suits done up.

Upon reasonable request, competitors/crews must provide information to the AORC Media Coordinator.

Competitors may be asked to participate in promotional activities eg: Media/VIP rides. Competition vehicles and crews should be made available upon reasonable request for public display and viewing.

At any time where there is an opportunity for television filming or other promotional activity, (e.g. Scrutiny or public display) competitors and crews shall always be mindful of the image they portray to the public when going about their business.

## **17. PRIZE MONIES**

- (i) Outright prize money is to be paid on the following basis:
  - (a) first place - a minimum of an amount equal to one entry fee for the event, inclusive of sundry levies and add-ons.
  - (b) second - a minimum of an amount equal to two thirds of the entry fee for the event, inclusive of sundry levies and add-ons.
  - (c) third - a minimum of an amount equal to one third of the entry fee for the event, inclusive of sundry levies and add-ons.
- (ii) The provision of prize money based on class placings is optional.

## **18. JUDICIAL PROCEDURES**

- (i) The object of these rules is to provide for the expeditious inquiry by the Stewards into, and determination of, any matter referred to them and of any alleged dispute, protest or offence.
- (ii) Inquiries pursuant to these rules shall be undertaken jointly by the Stewards.
- (iii) Inquiries shall be inquisitorial in nature, and the Stewards may regulate any inquiry in such manner as they see fit in all the circumstances of the case, subject only to the rules of natural justice.
- (iv) To facilitate the conduct of an inquiry a person, if requested by the Stewards, shall;
  - (a) upon receiving a request to do so, appear before the Stewards,
  - (b) fully cooperate in good faith with the Stewards,
  - (c) provide a full and truthful account to the best of their knowledge to the Stewards,

- (d) fully and truthfully answer any questions asked by the Stewards, and
- (e) not make any false or misleading statement to, or make a statement either calculated or likely to mislead the Stewards.
- (v) Each person thought by the Stewards to be able to assist them may be required to attend the inquiry. Notice to attend shall normally, but not necessarily, be in writing and shall include brief details of the matter under investigation.
- (vi) If in the opinion of the Stewards a person:
  - (a) fails to comply with the provisions of 17(v), or
  - (b) in any way obstructs an inquiry being undertaken by the Stewards, that person shall be deemed to have committed an offence against these rules and may be dealt with by the Stewards.
- (vii) Before commencing any inquiry the Stewards shall inform each relevant person:
  - (a) of the subject of the inquiry,
  - (b) of the nature of the matter referred to them, or of the alleged dispute or offence, and
  - (c) that as a result of the inquiry penalties may be imposed.
- (viii) Normally the calling of witnesses and the majority of questioning shall be conducted by the Stewards.
- (ix) Any person or persons who have been advised that as a result of the inquiry action might be taken against them must be made aware of all evidence against them and be given the opportunity to call evidence on their own behalf, ask questions and make submissions in relation to the matter.
- (x) Should guilt be established any submission to be put to the Stewards with regard to penalty shall be made, to avoid the necessity for a separate re-convening of the hearing to consider an appropriate penalty.
- (xi) Decisions shall normally take effect immediately after they are made.
- (xii) Affected persons shall be advised of any decision as soon as is practicable after it has been made.
- (xiii) Where possible, written decisions shall be provided as soon as practicable after the completion of the inquiry.
- (xiv) In addition to penalties provided in the National Competition Rules the Stewards may also apply;
  - (a) a penalty by way of the deduction of Championship points, on a crew member in any section of an event for a breach of the NCR, the Supplementary Regulations or Sporting Regulations, or
  - (b) a penalty by way of the addition of time, up to a maximum of 60 minutes per breach, to the total elapsed time in any section of the event for a breach of the NCR, the Supplementary Regulations or Sporting Regulations.
- (xv) Each person affected by or concerned in an inquiry shall be bound by the decisions or determinations of the Stewards of the Meeting, subject only to the rights of appeal pursuant to Part XIII of the NCRs.
- (xvi) The CAMS Infringement Notice may also be utilised as follows in order to assist in the timely application of penalties where a Competitor/Driver accepts that he/she has been in breach of the rules (refer Appendix A):
  - (a) The Clerk of the Course is to determine an alleged breach in the rules and that a penalty should be applied.
  - (b) If the Penalty to be applied for the breach is not prescribed in the NCR, Sporting Regulations or Supplementary Regulations or Further Regulations, the Clerk of the Course is to contact the Stewards to discuss and agree on the recommended penalty.

- (c) The Competitor/Driver of the alleged breach has the option of acknowledging the breach of rules and accepting the penalty or may request a Stewards Hearing into the matter.
- (d) If the Competitor/Driver does not admit the breach, a CAMS Charge Sheet is to be issued and a Stewards Hearing shall be convened. The Stewards have the authority to vary the penalty if a breach has been established.
- (e) The penalty is issued under the authority of the Stewards.
- (xvii) Organisers and Stewards are to have unrestricted access to in-car video footage for use in a judicial situation. Failure to comply shall result in penalties to be applied.

## 19. PENALTIES

- (i) The following are offences against these regulations, and are to result in the imposition of the specified penalties:
  - (a) Failure to comply with specified control procedure: – *time penalty of 30 minutes*
  - (b) Shortcutting or other deviation from the course:
    - first breach during the event: – *time penalty of 30 minutes*
    - second breach during the event: – *exclusion\**
    - any breach during the prologue – *time penalty of 3 minutes per instance*
  - (c) Causing damage to property, deemed by the Clerk of the Course to have been deliberate: – *exclusion\**,  
**plus any additional penalty which may be imposed by the Stewards**
  - (d) Refuelling whilst the vehicle engine is not switched off – *exclusion\**
  - OR**  
 whilst any person is inside the vehicle – *exclusion\**
  - OR**  
 whilst the vehicle is not totally inside any designated refuelling area – *exclusion\**
  - (e) Breach of *parc fermé* regulations – *time penalty of 100 minutes*
  - (f) False Start / Jumping the Start
    - Prologue – *time penalty of 1 minute*
    - Event proper – *time penalty of 5 minutes*
  - (g) Receiving outside servicing, other than as provided for in Article 4.9 – *exclusion\**
- (ii) Any time penalties imposed are to be applied to the relevant section at the conclusion of the event.
- (iii) Penalties may only be imposed by the Stewards

*\* Under the provisions of NCR 192 a penalty of exclusion may only be imposed by the Stewards*

**ENDS**



# INFRINGEMENT NOTICE

V 4.0

Document No: .....

**It is alleged that:**  
 Competitor / Driver's Name: ..... State: ..... CAMS Licence #: .....  
 Category: ..... Car Number: ..... In .....  
Event No.  
 at: .....  
Venue name Time: ..... Date: .....

**Committed the following offence(s),**  
 Rule: .....  
 Offence: .....  
 .....

*This notice is issued in respect of an alleged breach of rules at a meeting which is being conducted under the International Sporting Code of the Federation Internationale de l'Automobile (FIA), the National Competition Rules (NCR's) of the Confederation of Australian Motor Sport Ltd (CAMS), the relevant category sporting and the technical regulations as approved by CAMS, the Supplementary Regulations and any Further Regulations, or any instructions or Bulletins issued at the meeting.*

**PENALTY:**  
 Issued by: ..... as the .....  
Name of official Official's Title for the Meeting  
 on behalf of the **Stewards of the Meeting.**  
**The Penalty is:-** Tick relevant box(s)  
 Reprimand  Fine \$ .....  Loss of ..... Championship / Series Points  
from the relevant Championship / Series  
 Suspended Fine: \$ ..... with \$ ..... Suspended until the .....  
Providing there is no further breach of the rule listed above within this time period  
 Time Penalty of ..... seconds is to be added to the Competitor's time for .....  
Event No(s).  
 Exclusion from .....  
Event No(s)  
 Other .....

**I DO NOT ADMIT TO THE BREACH OF RULES AS DESCRIBED ABOVE:**  **Tick this Box.**  
 A Stewards Hearing will be convened for you to attend, where you will have the opportunity to state your case in person, call witnesses and present evidence supporting your case. The Clerk of the Course may appoint a Prosecutor on his behalf. You will also be issued with a CAMS Charge Sheet and advised of a place and time for the matter to be heard.  
**Note: STEWARDS HAVE THE AUTHORITY TO IMPOSE ADDITIONAL PENALTIES TO THOSE DETAILED ABOVE IF A BREACH OF RULES IS ESTABLISHED.**

**ADMISSION TO THE BREACH OF RULES AS DESCRIBED ABOVE:**  **Tick this Box.**  
 I, the above named Competitor / Driver or the authorised team representative have signed this section of the Infringement Notice, admitting to this Breach of Rules and accept the penalty described above. I further understand and acknowledge my rights to the NCR's Part XIII – Appeals have been waived in this matter.

Signed ..... Date ..... Time .....  
Competitor / Driver / Authorised Team Representative  
**Name:** ..... (Please Print)

**We the Stewards of the Meeting, find the Competitor in Breach of the Rules by their own admission, and impose the above Penalty.**

.....  
Chief Steward Steward Steward  
 Date ..... Time .....

**Distribution List:**  
If applicable  
 CAMS / Stewards    Competitor / Driver    Chief Time Keeper    Secretary of the Meeting (Notice Board)  
 Clerk of the Course    Category Manager    Race Director    Media